



MORAVAN – AEROPLANES a.s.

ZLIN Z 143 L Primary/Advanced Training, Touring and Business Flying Aircraft



High Quality, Extremely Responsive, Very Rugged
Construction - our tradition since 1934

Moravan – Aeroplanes a.s., 765 81 Otrokovice, Czech Republic
tel.: +420 576 083 900, fax: +420 576 083 929, e-mail: m.aeroplanes@zlinaircraft.cz
<http://www.zlinaircraft.cz/>

MORAVAN – AEROPLANES a.s.

MANUFACTURER OF **ZLIN** ALL-METAL TRAINING, TOURING AND AEROBATIC AIRCRAFT



Letiště 1578
765 81 Otrokovice
Czech Republic

www.zlinaircraft.cz



MORAVAN – AEROPLANES, a.s. is Czech aircraft manufacturer with the long tradition in production of training, sporting, aerobatic, utility and touring aircraft bearing the name ZLIN which were delivered to over 60 countries worldwide. Since 1934 more than 5,600 aircraft have left the company production facilities.

The present production of ZLIN airplanes which are **best known for their great flight characteristics** includes the latest modifications to all-metal Z 40 series airplane with piston engines, the Z 242 L, Z 142 C, Z 143 L and Z 143 LSi.

Our **ZLIN Z 242 L training and fully aerobatic** two seater, is modernized version of Z 142 C aircraft (still in production) powered by a 200 HP Lycoming engine. This aircraft is able to perform aerobatic maneuvers +6 –3,5 g and in conjunction with **well-balanced controls** and its **IFR** capability for an affordable price moves it ahead of any other aircraft available today. It's maneuverability makes it an attractive machine not only for aviation enthusiasts. More, thanks to **Acceleration Monitoring Unit (AMU-1)** installed on the Z 242 L as a standard we were able to extend the aircraft's fatigue life (for example to **11.000 hours** at one of the leading flight schools in CANADA).

Delightful, light, crisp and responsive handling qualities best describe the four seater **ZLIN Z 143 L**. With its 235HP Lycoming engine, **autopilot** and IFR capabilities this aircraft is demanded not only for pilot training but also for cross country, business and family flying purposes.

Ability to modify this aircraft to the two seats long range version in just a couple of hours is demanded option. And **new ZLIN Z 143 LSi with fuel injection system** is just coming to sale.



Z 242 L



Z 137 T



Z 242 L



Z 143 L

To provide the best services to all of our customers flying ZLIN aircraft or wishing to own one, MORAVAN – AEROPLANES a.s. is expanding a worldwide **ZLIN Distributor** network and **ZLIN Authorized Service Center** network. Contact us if you were interested in being a part of the team behind the ZLINs in your country.

We believe that there is a big potential in the small aircraft market, both in civil and military sectors for the aircraft whose aerobatic versions have **6 times won a Title of The Absolute World Aerobatics Champion**.



ZLIN Z 143 L Performance & Specification

...FROM THE PRESS...

"With our expert aerobatic instructor, we have taken **aerobatic experts class** as well as beginners and taught them new tricks. Side-by-side seats really provide the instructor the ability to judge the student's mental as well as physical condition during the lessons. ... not only that, but ZLIN is **built to military specifications and is very stout.**" – Craig Johnston



"I have previously owned an aerobatic ZLIN Z 242 L and recently upgraded to the Z 143 L. Having owned, operated and flown dozens of other aircraft over the past thirty years I have found the ZLIN to **have the lightest, most well-balanced controls and delightful flying characteristics.**" – Spencer Lane

"..... we could find **not a single bit of paint run** or overspray **in the complex scheme.**" – Private Pilot Magazine

"My plane is being serviced by an extremely qualified airplane inspector/ mechanic with 25 years of experience. He said this is the **best built plane he has ever seen** from another country. When I fly with my wife and my son I am betting everything on this special machine." – Robert Blazer, USA



Series of
Z 242 Ls
in service
with the
Mexican Navy



ZLIN Z 143 L Performance & Specification

Moravan - Aeroplanes a.s. a company with tradition of building a small airplanes since 1934 introduces a current production of a versatile airplane ZLIN Z 143 L and ZLIN 143 LSi.

Based on previous types Z 42 / Z 142 / Z 43, of which more than 750 pieces were made, the ZLIN Z 143 L has been in serial production since 1994. Among other fully aerobatic and training airplanes like **ZLIN Z 242 L two-seat airplane** also available.

From the recent Z 143 L very successful series we have developed the **Z 143 LSi** improved, more user friendly aircraft. Main difference was made in the Lycoming engine which thanks to its fuel injection system is capable of advanced maneuvers and spins.

The ZLIN Z 143 L is designed for:

- **Air taxi, touring, family and light business flying** (for fast and save transfers between a remote areas or business places - with additional fuel tank (long range version) the flight range reaches 2759 km, able to land on rough surfaces)
- **Basic and advanced training in civil or military air schools.** (side-by-side seats provide the instructor the ability to judge the student's mental as well as physical condition during the lessons. More, the craftsmanship of people behind the ZLIN make the airplane comply with most military specification and is very stout)
- **Ground observation, naval and coast patrol** (e.g. monitoring pipelines with optional built-in recording devices such as standard or infrared camera)
- **Night and IFR training and flying** (great flight characteristics and additional instruments make the ZLIN easy to fly at night or low visibility conditions)
- **Optional glider and banner towing**

The plane can be operated in Normal and Utility categories, within load limitations of +4.4 / -1.76 g factor.

The plane is certified in all 25 countries of European Union (TC EASA.A.028), USA (TC Nr.A76EU), Switzerland, Bulgaria and Macedonia.

GENERAL DESCRIPTION OF THE PLANE

The Z 143 L is a single engine, four-seat, low wing, cantilever monoplane of whole metal structure. Unlike the airplanes fully made of composite materials ZLIN is built to provide great ability to access any vital part of the airplane for **easy check and repairs**. Operating expenses are kept low thanks to replaceability of the parts.



The seat arrangement is 2 + 2. This side-by-side seating offers **incredible visibility** from the canopy to all passengers useful for recognition flights, patrolling and search on the ground. It is powered by a world premier **TEXTRON LYCOMING** piston engine, type O-540-J3A5 giving the plane more than sufficient power of 235 hp through a three-blade, hydraulic pitch controlled, constant-speed propeller, **Mühlbauer** type MTV-9-B/195-45a with diameter 1950mm. The Aircraft complies with the very strict Swiss noise regulations and is certified in the lowest noise class D to be allowed for flights in the high density residential areas.

FUSELAGE

The fuselage is of mixed structure. The central supporting part is a latticework creating almost **a safety cage around the pilot and the passengers**, being welded of steel tubes and covered by a body made of hard light alloy sheets and of glass-fiber composite. The rear part is a semimonocoque construction. The forward sliding canopy is making it easy to enter and exit the airplane.

WING

The wing is of all-metal structure provided with a main and an auxiliary spar. The **main spar is nitrogen - pressurized** with pressure indicator on the instrument panel. A safety feature very appreciated by every pilot. Two wing halves are attached to the fuselage. The wing flaps and ailerons are slotted, all-metal, and identical in construction and dimensions



ZLIN Z 143 L Performance & Specification

therefore exchangeable. The ailerons are provided with fixed balance tabs all with other controls making the plane to be **extremely responsive**. The wing ends are terminated with **composite wing tips to reduce the induced drag**.

EMPENNAGE

All parts are of a strong all-metal cantilever structure covered with hard aluminum sheet. Both **the rudder and the elevator are partially mass-balanced** helping the pilot to take the control of the plane even in worse flight condition. The elevator is provided with two balance tabs, the one being controllable for longitudinal trim. That way you can fly with "two fingers" all day long without plane "wondering around". The rudder is provided with a fixed balance tab.

LANDING GEAR

The non-retractable, tricycle landing gear consists of the main landing gear and the nose gear. The main landing gear wheels are equipped with hydraulic disc-brakes including **automatic clearance adjustment**.

CONTROL SYSTEM

The aircraft is provided with dual stick-type and rudder controls. **Elevator and ailerons are tie-rod operated**, the rudder is tie-rod and additional cable operated. The nose wheel is coupled with the rudder control. The **aircraft is equipped with elevator and rudder trims**, ailerons are trimmed by fixed tabs.

ELECTRICAL SYSTEM

The electrical system is of single-wire type (+ pole). The nominal DC voltage is 28 V. The primary power source is the 1600 W generator (alternator). The power source is secured by a second battery to guarantee internal power supply for emergency landing. As an auxiliary power source serves a 19 Ah capacity battery. All electrical systems and equipment are protected by circuit breaker switches.

AVIONICS

Avionics packages based on Bendix King Silver Crown equipment, available in option.

GUARANTEE AND WARRANTY

MORAVAN – AEROPLANES a.s. provides warranty on main aircraft structures of 1000 flight hours, on the assumption of normal use of the plane, or for a three years period after acceptance, whichever comes first.

MORAVAN–AEROPLANES a.s. guarantees technical service for a lifetime of 6.000 flight hours for the airframe with respect to operational limitations and maintenance procedures. The service period will be prolonged based on operational and technical structure conditions (with AMU installed). For this purpose our technicians teamed up with **Aeronautical Research and Test Institute in Czech Republic** and developed **Acceleration Monitoring Unit** allowing us to monitor flight loads during operation.

12 months for engine under Lycoming warranty card, 12 months for propeller under Mühlbauer warranty card and 18 months for Bendix King avionics under B/K warranty card.



TECHNICAL SERVICE

All technical information concerning the plane manufactured by MORAVAN–AEROPLANES a.s. are distributed by bulletin service. **Pilot and technician training** of customer's staff is organized at MORAVAN–AEROPLANES a.s. training center.



ZLIN Z 143 L Performance & Specification

Engine

Manufacturer	TEXTRON Lycoming, USA		
Type	O-540-J3A5		

Power

max take-off 175 kW	235 HP	2400 RPM
max continuous 175 kW	235 HP	2400 RPM
cruising 75 % MC 130 kW	175 HP	2200 RPM
cruising 60% MC 104 kW	140 HP	2000 RPM

Aircraft Dimensions

Wing span	10.14 m	33.25 ft
Length	7.58 m	24.86 ft
Height	2.91 m	9.55 ft
Wheel track	2.44 m	8.00 ft

Ceiling

Service Ceiling	4170 m	13681 ft	5700 m	18701 ft
-----------------	--------	----------	--------	----------

Fuel consumption

Nominal values alt 0 m ISA as provided by engine manufacturer

max continuous PWR	96 l/h	25,4 US gal/h
cruising 75% MC	55,5 l/h	14,7 US gal/h
cruising 60% MC	44 l/h	11,6 US gal/h

NORMAL

UTILITY

Airspeeds

Maximum level speed	262 km/h	141 kt	267 km/h	144 kt
Cruising 75% MC	232 m/h	125 kt	235 km/h	127 kt
Cruising 60% MC	209 km/h	113 kt	216 km/h	117 kt
Stall Speed (IAS, flaps 37°)	100 km/h	54 kt	90 km/h	49 kt
Max climb speed	4.9 m/s	964 ft/min	7.4 m/s	1457 ft/min

Take-off distances

ALT 0 m ISA, max continuous PWR, dry concrete RWY, flaps „TAKE OFF“

Take-off run	295 m	970 ft	170 m	558 ft
Take-off distance to 15 m (50 ft)	640 m	2100 ft	450 m	1477 ft

Landing distances

Landing run	380 m	1247 ft	305 m	1000 ft
Landing distance from 15 m (50 ft)	765 m	2510 ft	590 m	1936 ft

Range & Endurance

(ALT 3030 m, 10000 ft)

65% engine power	1070 km	578 NM	506 km	273 NM
58% engine power	1314 km	709 NM	570 km	308 NM
Maximal Endurance (58% engine power)	6° 14'		2° 47'	



ZLIN Z 143 L Performance & Specification

Weights

Empty weight	850 kg	1874 lbs	850 kg	1874 lbs
Maximum take off weight	1350 kg	2976 lbs	1080 kg	2380 lbs
Crew: 2 pilots	200 kg	441 lbs	200 kg	441 lbs
PAX: 2 passengers	200 kg	441 lbs	-	-
Baggage: back lockable compartment	60 kg	132 lbs	-	-
Baggage: cabin compartment	20 kg	44 lbs	-	-

Fuel capacity

Main fuel tanks	2 x 61 l	2 x 16.1 US gal	2 x 61 l	2 x 16.1 US gal
Auxiliary fuel tanks	2 x 51 l	2 x 13.4 US gal	-	-

Oil capacity

Oil capacity (Engine)	11.4 l	12 US qts	7.6 l	8 US qts
-----------------------	--------	-----------	-------	----------





ZLIN Z 143 L Performance & Specification

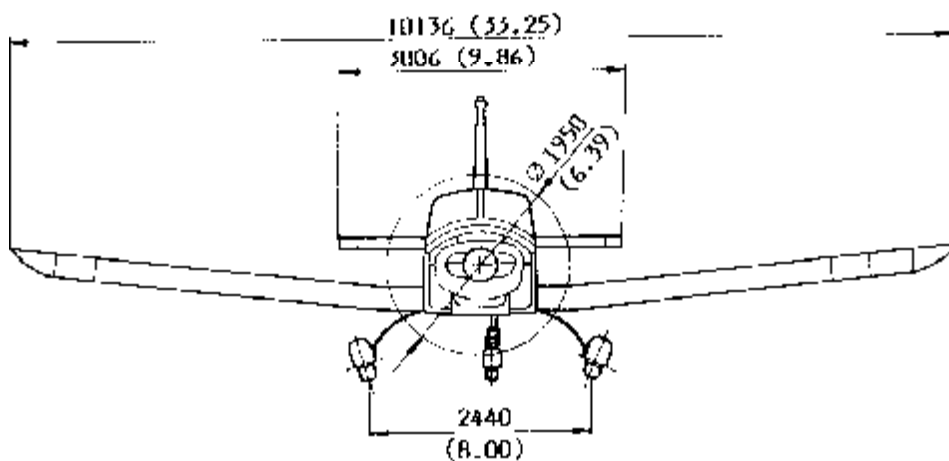
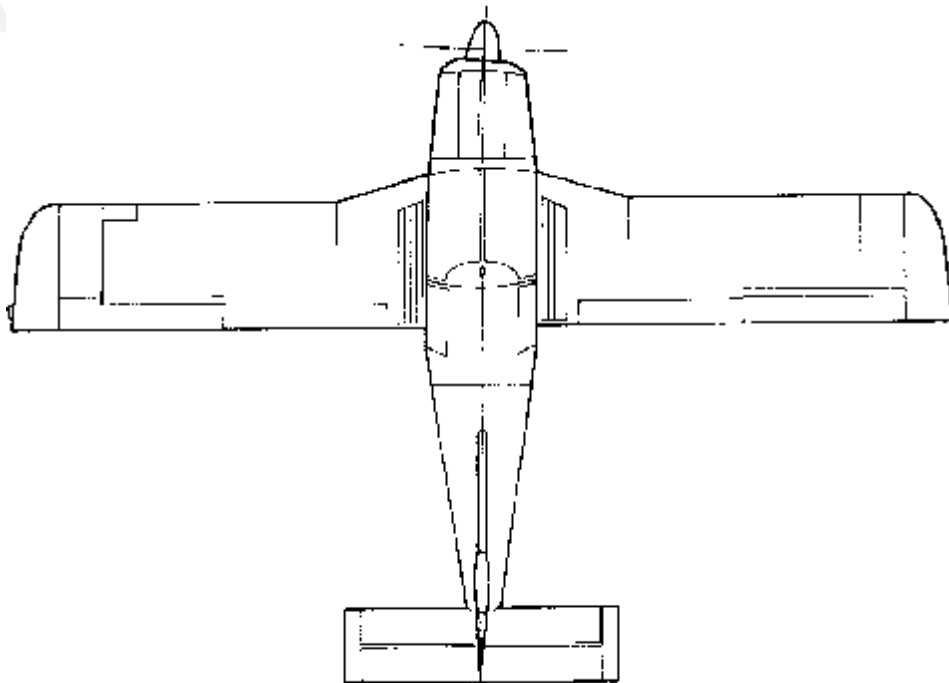
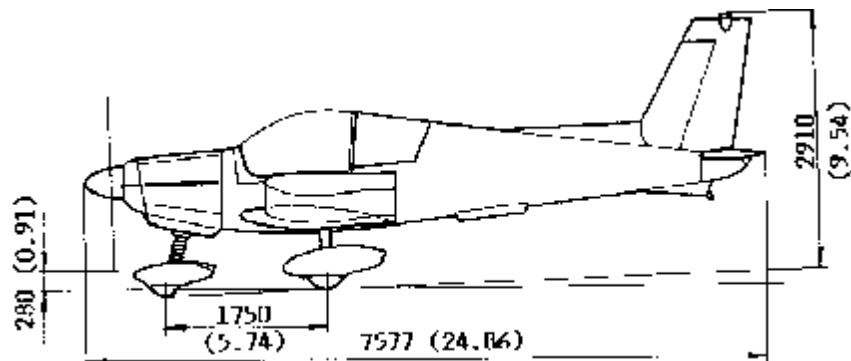



ZLIN Z 143 L

Performance & Specification

1. Standard Aircraft

Power Plant & Accessories

Lycoming O-540-J3A5 Engine 235 HP @ 2400 RPM, certified for 100 LL fuel
Mühlbauer MTV Propeller, 3 blades constant speed
Carburettor, Dual ignition
Propeller spinner
Dry air filter, Engine oil cooler
Electric starter
Engine mounts with dampers
Exhaust silencer

Electrical System

24 volt, 19 Ah GILL battery
Emergency T & B indicator power supply
External auxiliary power supply
Fused avionics circuits
Master switch, Alternator
Rocker switches & circuit breakers

Fuel System (indicators in metrics)

2 x 61 litres (16.1 US Gal.) Main tanks (wing roots)
2 x 51 litres (13.4 US Gal.) Auxiliary tanks (wing tips)
Fuel priming cup
Fuel pump (engine driven)
Fuel pump (electric)
Individual fuel tank drains

Engine Instruments

Quadruple fuel gauge
Oil temperature / pressure / Fuel pressure / carburetor temperature
Systems Annunciator lights
C.H.T. indicator and E.G.T. gauge
Voltammeter
Engine RPM indicator
Manifold pressure indicator
Heated Pitot tube, static pressure & ram pressure probes

Flight Instruments

Air speed indicator, Altimeter
Electrical Attitude Gyro
Electrical Directional Gyro
Vertical speed indicator
Turn and Bank Coordinator
Magnetic compass, Aircraft clock
Alternate static pressure source

Controls

Nose wheel /dual rudder control pedals
Dual toe activated brakes
Dual stick controls (tie rod operated)
Push/pull engine throttle control

Push/pull propeller speed control
Mixture control
Carburetor warm up control
Fuel selector (left/right/both)
3 position flap actuating lever
Rudder and elevator trim controls
Parking brake

Interior

4 place, 2 + 2 configuration
Adjustable cloth and vinyl seats
Adjustable Pilot and Copilot seats
Adjustable cabin ventilation
Cabin heater, Cabin lighting
Enunciator panel glare shield
Electrical & Avionic Circuit Breakers
Metal instrument panel with removable subpanels
Map & Storage pockets
Baggage compartment & Net
Canopy lock

Exterior

Anodized aluminum skin
Four-color graphic paint scheme (© DuPont)
Fixed tricycle nose-type landing gear
Steerable Nose Wheel
Good Year tires, Wheel Fairing
Hydraulic disk brake system
Oleo nose wheel strut with shimmy damper
Wing & Fuselage quick release access panels
Lockable, Key operated baggage door
Canopy and Pitot tube covers
Heated Pitot system
Engine & propeller wrenches
Aircraft tow bar

Exterior lights

Halogen taxiing and landing lights
Position and beacon lights, Strobe lights

Fire Protection & Safety Features

Ejection canopy with dual quick release handles
Four-point seat-belts (4 pcs)
Fireproof hoses in engine compartment
Firewall, Fire extinguisher
Main spar pressure gauge

Documentation

Flight Manual
Engine and Propeller Operator's Manual
Service and Maintenance Manuals
Spare Parts Catalogue
Export Certificate of Airworthiness (if applicable)



ZLIN Z 143 L

Performance & Specification

2. Instrument Packages (for additional cost)

A/ VFR BASIC Package

KY 96A	COMM
KT 76A	XPNDR
AK 350	Altitude Encoder
DavidClark	Headsets H 10-36 (2 pcs)

Optional changes available on the base of customer's requirements

B/ IFR + VFR BASIC Package:

GMA 340	Audio-MKR-Voice IC (incl. CI 102)
KX 155A	COMM1-NAV1-GS1 (incl. CI 292-1, CI 158C, CI 507)
KI 204	Indicator
KY 96A	COMM2 (CI 122)
KR 87	ADF (incl. KA 44B)
KI 227	ADF Indicator
KT 76C	XPNDR (incl. KA 61)
KN 62A	DME (incl. KA 61)
AK 350	Altitude Encoder
SCOTT	Outside Air Thermometer
DavidClark	Headsets H 10-36 (2 pcs)
UI 5934D-3	2 nd Altimeter
LUN 1241	2 nd Attitude Gyro (electric)

Alternative Static Pressure Source
Cabin and Instruments lighting

Optional Changes available





ZLIN Z 143 L

Performance & Specification

3. Instruments on request

3.1	2 nd Attitude Gyro (electric)	LUN 1241.A8G8W
3.2	2 nd Attitude Gyro (electric)	AIM 1200
3.3	2 nd Directional Gyro (electric)	AIM 205-IBL
3.4	ELT	E-01
3.6	Engine Hour Recorder	HOBBS
3.7	Outside Air Thermometer	Scott
3.8	2 nd Airspeed Indicator	LUN 1106.J3B5
3.9	2 nd Altimeter	UI 5934D-3
3.10	2 nd Magnetic Compass	LUN 1224
3.11	2 nd Turn Coordinator	S-TEC 6407-28L
3.12	2 nd Vertical Speed Indicator	LUN 1144.A3B1
3.13	Autopilot System	S-TEC 55
3.14	AMU 1.01 Acceleration monitoring unit	
3.15	Fuel System indicators in gallons	
3.16	G-Meter	

4. Cockpit Accessories on request

4.1	Canopy Shade Curtains
4.2	Blind Flying Curtains for IFR Training
4.3	Instrument Lighting
4.4	Cabin Lighting
4.5	2nd Intercom Pushbutton
4.6	Hot Mike Switch
4.7	Carpets
4.8	Leather Interior
4.9	Sliding Canopy Window (1 pc)
4.10	Internal Rear View Mirror
4.11	DavidClark Headsets H 10-30 (2 plugs)

5. Aircraft Accessories and Spare Parts

5.1	Glider Towing Device
5.2	Glider Towing Winch Device
5.3	Concorde's RG battery (instead of GILL)
5.4	Mitas tyres (instead Good Year tyres)
5.5	External Rear View Mirrors (2 pcs)
5.6	500 FH Recommended Spare Parts Set
5.7	Winter Operation Equipment
5.8	Engine Winter Coating
5.9	Anchoring Device
5.10	Maintenance Jack Stands
5.11	Brake Filling Device
5.12	Parachute Support
5.13	Heating of Passenger Compartment
5.14	Rear Curtains
5.15	Protecting Seat Covers
5.16	Ferry Flight Fuel
5.17	Aircraft Packing Into Container (1 a/c in 40" container)
5.18	Pilot Type Rating Training
5.19	Engineer Type Rating Training
5.20	Airplane Assembly by Manufacturer at Place of Delivery



ZLIN Z 143 L

Performance & Specification

6. General Purchase Conditions (depend on specific contract):

- 6 months delivery lead time since receiving downpayment. The delivery time is valid for first airplane in case of sale of more airplanes. Delivery terms EXW Otrokovice (Incoterms 2000).
- 50 % downpayment from the total price and the rest before delivery
- Warranty 3 years or 1000 flight hours on main aircraft structures
- Financial plan available to qualifying customers
- Irrevocable Letter of Credit acceptable as well

